

Model TR1 - Tru-Trac™

Encoder and spring loaded measuring wheel



Linear Encoders



Features

- Encoder and Measuring Wheel Solution Integrated Into One Compact Unit
- Spring Loaded Torsion Arm Makes Wheel Pressure Adjustments So Easy
- Easily Installed In a Vertical, Horizontal, or Upside-Down Orientation
- Operates Over a Variety Of Surfaces At Speeds Up To 3000 Feet per Minute
- Integrated Module Simplifies Your System Design, Reducing Cost

An integrated encoder and spring loaded measuring wheel assembly available in one, easy-to-use compact unit. The Tru-Trac™ is a versatile solution for tracking velocity, position, or distance over a wide variety of surfaces in almost any application. Its spring-loaded torsion arm provides a simple-to-adjust torsion load, allowing the Tru-Trac™ to be mounted in almost any orientation, even upside-down. The threaded shaft on the pivot axis is field reversible providing mounting access from either side. The Tru-Trac™ housing is a durable, conductive composite material that will eliminate static build up. With operating speeds up to 3000 Feet Per Minute and a wide variety of configuration options, it is easy to see the Tru-Trac™ is the ideal solution for countless applications.

Common Applications

Web Tension Control, Paper Monitoring, Glue Dispensing, Linear Material Monitoring, Conveyor Systems, Printing, Labelling, Document Handling

Model TR1 Ordering Guide

Blue type indicates price adder options. Not all configuration combinations may be available. Contact Customer Service for details.

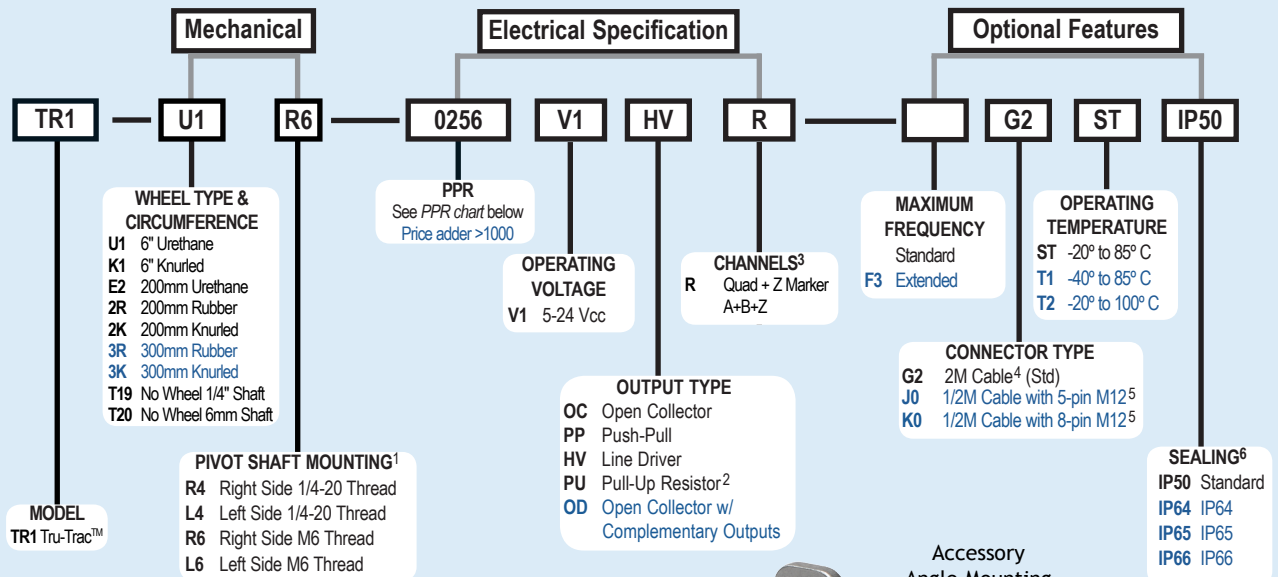

For specification assistance call Customer Service at +44 (0)1978 262100

Model TR1 PPR Options

0001 thru 0189*	0198	0200	0250
0256	0300	0315	0360
0500	0512	0580	0600
0800	1000	1024	1125
1250	1500	1800	2000
2500	2540	3000	3600
4096	5000	6000	7200
10,000			8192

*Contact Customer Service for Availability

New PPR values are periodically added to those listed. Contact Customer Service to determine all currently available values. Special disk resolutions are available upon request and may be subject to a one-time NRE fee.



Accessory Angle Mounting Bracket for TR1 Tru-Trac™ can be ordered separately as part #140104 Dimensional Drawing Located in Accessories Section.

NOTES:

- 1 Shaft is reversible in the field.
- 2 With input voltage higher than 16 Vcc, The operating temperature is limited to 85°C.
- 3 Contact customer service for non-standard index gating or phase relationship options.
- 4 For non-standard cable lengths - Contact Customer Service for availability and cost.
- 5 5-Pin not available with Line Driver(HV) output. Additional cable lengths available Please consult Customer Service.
- 6 Increased starting torque with IP64+ selection.

Model TR1 - Tru-Trac™

Encoder and spring loaded measuring wheel



Model TR1 Specifications

Electrical

- Input Voltage 4.75 to 28 VCC max for temperatures up to 85° C
4.75 to 24 VCC for temperatures between 85° C to 100° C
- Input Current 100 mA max (65 mA typical) with no output load
- Output Format Incremental- Two square waves in quadrature with channel A leading B for clockwise shaft rotation, as viewed from the wheel side. See *Waveform Diagrams* below.
- Output Types Open Collector- 20 mA max per channel
Push-Pull- 20 mA max per channel
Pull-Up 20mA max per channel
Line Driver- 20 mA max per channel (Meets RS 422 at 5 Vcc supply)
- Index Once per revolution.
0190 to 2540 PPR: Gated to output A
0001 to 0189 PPR: Ungated
See *Waveform Diagrams* below.
- Max. Frequency Standard Frequency Response is 200 kHz for PPR 1 to 2540
500 kHz for PPR 2541 to 5000
1 MHz for PPR 5001 to 10,000
Extended Frequency Response (optional) is 300 kHz for PPR 2000, 2048, 2500, and 2540
- Noise Immunity Tested to BS EN61000-6-2; BS EN50081-2; BS EN61000-4-2; BS EN61000-4-3; BS EN61000-4-6, BS EN500811
- Symmetry 180° (±18°) electrical
- Quad. Phasing 90° (±22.5°) electrical
- Min. Edge Sep 67.5° electrical
- Accuracy Within 0.017° mechanical or 1 arc-minute from true position. (for PPR>189)

Mechanical

- Max Shaft Speed 6000 RPM. Higher speeds may be achievable, contact Customer Service.
- Shaft Material Stainless Steel
- Shaft Tolerance g6
- Radial Shaft Load .. 2.5kg max. Rated load of 1.25kg to 1.75kg for bearing life of 1.2×10^{10} revolutions
- Axial Shaft Load..... 2.5kg max. Rated load of 1.25kg to 1.75kg for bearing life of 1.2×10^{10} revolutions
- Starting Torque..... IP50 3.531×10^{-4} Nm
IP64 2.825×10^{-3} Nm
- Electrical Conn..... 2M cable (foil and braid shield, 24 AWG conductors), 5-Pin & 8-pin M12 (12 mm) in-line connector with 0.5M cable (braid shield)
- Mounting Pivot shaft can be mounted from either side of the Tru-Trac™ housing, and is reversible in the field. Specify 1/4-20 or M6 threads
- Housing Stainless steel fibres in a high temperature nylon composite
- Wheel Width..... 6.35mm to 10mm
- Weight 150 grams typical

Environmental

- Operating Temp..... -20° to +85° C for standard models
-40° to +85° C for low temperature option
-20° to +100° C for high temperature option
- Storage Temp..... -25° to +85° C
- Humidity 98% RH non-condensing
- Vibration 10 g @ 58 to 500 Hz
- Shock 80 g @ 11 ms duration
- Sealing IP50 standard; IP64 available

Model Tr1 Tru-Trac™

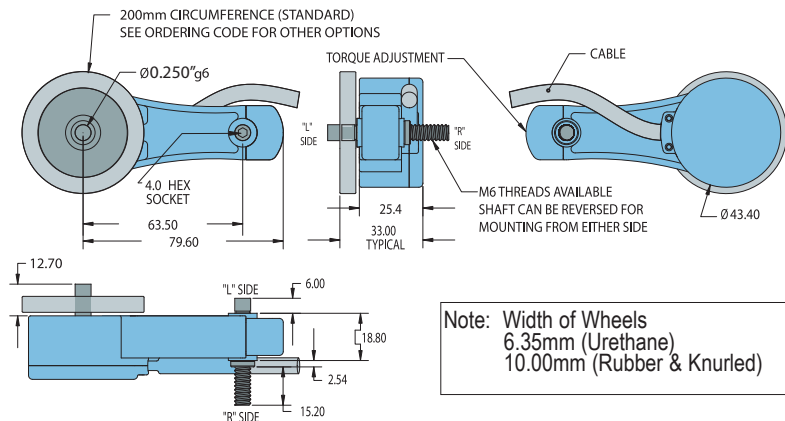

All dimensions are in mm with a tolerance of ± 0.127 mm or ± 0.254 unless otherwise specified

Model Tr1 Tru-Trac™ Applications

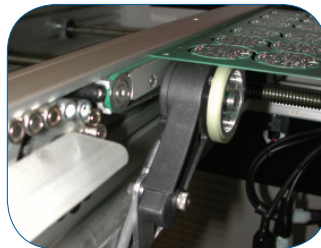

For Linear Applications the Tru-Trac™ can be mounted above or below the moving object, and the tension on the wheel adjusted for a wide range of applications such as packaging, conveyors, mail sorting, cut to length, labelling, gantries etc.



For Rotational Applications the Tru-Trac™ can be mounted in any orientation to monitor the position or velocity of many types of rotating equipment such as web tension control drums, rotary tables, printing, spooling, etc.

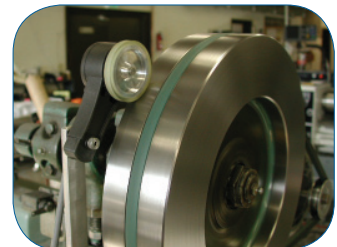

Waveform Diagrams

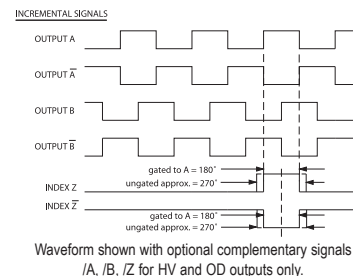

Wiring Table

Function	Cable Wire Color	5-pin M12 ²	8-pin M12 ²
0 Volts	Black	3	7
+ Vcc	White	1	2
A	Brown	4	1
A'	Yellow	--	3
B	Red	2	4
B'	Green	--	5
Z	Orange	5	6
Z'	Blue	--	8
Shield	Bare ¹	--	--

¹Cable shield (bare wire) is connected to internal case.

²Cable shield and M12 connector body is connected to internal case.

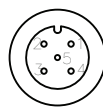

5-pin M12

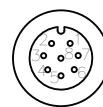

8-pin M12